

Rosenberger

Data, RF, Power and Hybrid

Connectivity for Robotics

ROBOTIC APPLICATIONS AND AUTOMATED TESTING SYSTEMS





Smart Connectivity for Next-Generation Robotics Performance

As robotic systems become increasingly intelligent, interconnected, and dynamic, connectivity evolves into a critical enabler of performance, precision, and reliability. Rosenberger, a global leader in RF and connectivity solutions, delivers advanced technologies that ensure seamless data transmission, robust signal integrity, and efficient power distribution across all robotic subsystems.

Our solutions are engineered to meet the complex requirements of modern robotics, supporting established communication and control protocols such as GMSL, FPD-Link, EtherCAT, PROFINET, EtherNet/IP, CAN, IO-Link, and serial interfaces. From high-speed coaxial data cables to differential systems for advanced sensor applications, Rosenberger offers a versatile portfolio designed for maximum performance in compact and light-weight form factors.

By combining proven standard components with customized system solutions, we enable OEMs and system integrators to achieve optimal system design and integration. Supported by comprehensive in-house expertise—from development and testing to highly automated manufacturing—our solutions stand for consistent quality, scalability, and cost efficiency.

Designed for demanding environments and highly dynamic motion sequences, Rosenberger connectivity solutions deliver exceptional robustness and long-term reliability.

As a globally positioned partner, we combine technological excellence with a collaborative mindset—empowering the next generation of robotics through smart, future-ready connectivity.

Rugged Coaxial Cables for Robotics and Drag Chain Applications

Highly dynamic robotics and drag chain environments place demanding requirements on cable systems. Rosenberger offers coaxial and differential cable solutions specifically designed to withstand high bending and torsional stresses.

The focus is on the seamless integration of cables and connectors, as well as on reliable, application-optimized cable assembly processes. Rosenberger is among the few manufacturers worldwide offering specialized solutions for these challenging applications.

Benefits

- Highly flexible coaxial and differential cables designed for millions of bending and torsion cycles
- Robust connectors with secure locking mechanisms and high mechanical durability
- High and stable signal integrity throughout the entire service life
- Support for common high-speed protocols such as GMSL1–3, FPD-Link, APIX® and others

See page: 14



Contactless Transmission Redefined

Maximum performance. Zero wear. Absolute flexibility.

Seamless connectivity and intelligent processes are essential to meet the increasing quality requirements of modern automation and robotics systems – up to and including zero-defect performance. Reliable, high-performance transmission of data and power is therefore indispensable.

However, conventional systems such as connectors or slip rings often reach their physical and technical limits. With RoProxCon®, a proprietary development by Rosenberger, communication in modern robotic systems is redefined. The technology enables reliable, contactless transmission of data and power.

Benefits

Robust, low-maintenance, and future-proof – the ideal solution for humanoid, industrial, and mobile robotics (AMR/AGV), as well as cobots.

See page: 16



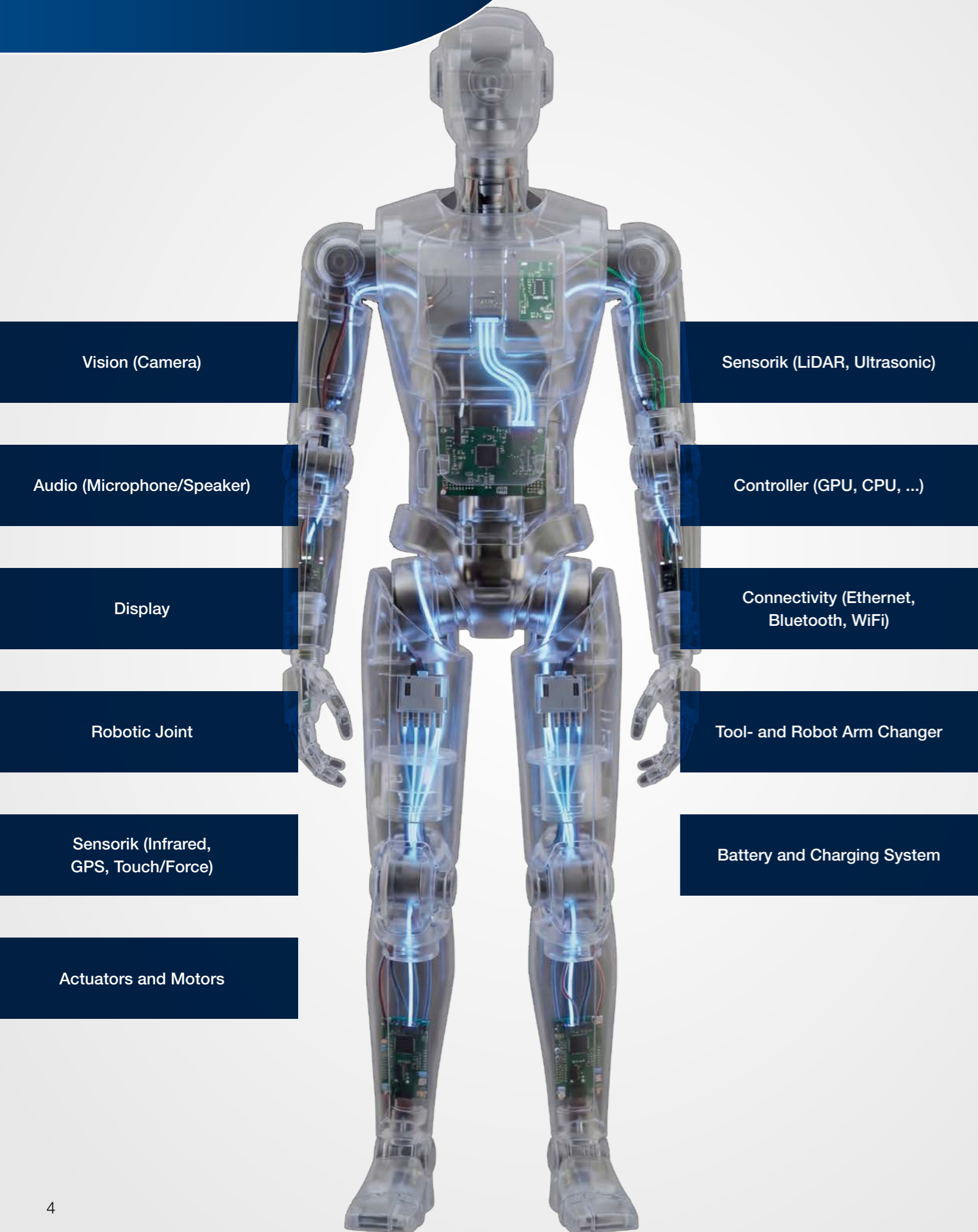

Engineering the Backbone of Robotics

From perception to motion, next-generation robotic systems are defined not by individual components, but by the intelligence of their integration. True performance emerges when sensing, decision-making, and actuation converge into a seamlessly orchestrated system.

Connectivity as a Strategic Layer

In this context, connectivity is no longer just infrastructure—it becomes a defining layer of system architecture. It determines how efficiently information flows, how precisely systems respond, and how reliably performance is sustained under real-world conditions.



Driving System-Level Performance

When integration is executed at the highest level, robotic systems gain measurable advantages: faster response times, greater precision, and enhanced adaptability. This system-level optimization is key to unlocking the full potential of automation in increasingly complex and dynamic environments.

Enabling the Robotics Ecosystem

Achieving this requires a holistic approach across all critical subsystems: Vision & Camera Systems · Sensors · Actuators & Motors · Connectivity · Tool Changers & End-of-Arm Systems · Battery & Charging Systems.

Robotic Systems

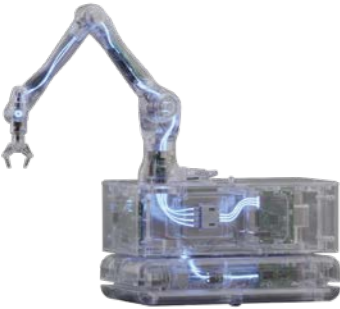
			Vision (Camera)	Audio (Microphone/Speaker)	Display	Robotic Joint	Sensor (Touch/Force, Ultrasonic, Temperature)	Sensor (LiDAR, IMU)	Actuator and Motor	Controller (GPU, ...)	Connectivity (Bluetooth, WiFi, GPS ..)	Tool- and Robot Arm Changer	Battery and Charging System
	<p>Humanoid Robotics</p> <p>Humanoid robots demand the highest levels of miniaturization, flexibility, and reliability in connectors. Compact, lightweight, and high-performance connectivity solutions are essential to enable advanced mobility, seamless sensor integration, and natural human-robot interaction.</p>		•	•	•	•	•	•	•	•	•	•	•
	<p>Industrial Robotics</p> <p>In industrial robotics, robust connectors ensure secure connections under demanding conditions. They enable fast installation, high system availability, and reliable operation in automated production environments.</p>		•			•	•		•		•	•	•
	<p>Mobile Robotics</p> <p>In mobile robotics, particularly in AMRs and cobots, reliable connectivity ensures a stable power supply and high-speed data transmission during dynamic operation, supporting flexible deployment and safe human-robot collaboration.</p>		•	•	•	•	•	•	•	•	•	•	•

Product	Key Application Feature	Technology	Data Rates	Vision (Camera)	Audio (Microphone/Speaker)	Display	Robotic Joint	Sensor (Touch/Force, Ultrasonic, Temperature)	Sensor (LiDAR, IMU)	Actuator and Motor	Controller (GPU, ...)	Connectivity (Bluetooth, WiFi, GPS ..)	Tool- and Robot Arm Changer	Battery and Charging System
RoProxCon® SoM	Contactless data transmission on the PCB for unlimited rotation	Contactless Data	3.125 Gbps	●			●		●				●	
RoProxCon® Data	Contactless data transmission for dynamic and hermetically sealed systems	Contactless Data	1.25 Gbps				●		●				●	
RoProxCon® Hybrid	Contactless power and data transmission for maintenance-free connections in moving or hermetically sealed systems	Contactless Data & Power	1.25 Gbps Power: 30 W				●		●				●	●
Camera Solutions	Automotive high-speed connectors	Differential / Coaxial	20 GHz / 40 Gbps	●										
Camera Solutions - Hy-SpeedVision	Industrial hybrid high-speed connector for SPE applications	Differential	3.5 GHz / 12 Gbps Power: 1.5 A per pin	●		●			●	●	●			
Circular Connector M8	Standard industrial circular connectors for Ethernet and automation applications	Differential	100 Mbps	●	●	●		●		●	●		●	
Circular Connectos M12	Standard industrial circular connectors for Ethernet and automation applications	Differential	100 Mbps / 10 Gbps	●	●	●		●	●	●	●		●	
SPE (Single Pair Ethernet)	Standard industrial connector for Single Pair Ethernet applications, 2-pin	Differential	4 GHz / 5 Gbps	●	●	●			●	●	●		●	
SPE (Single Pair Ethernet) Hybrid	Hybrid connector for data and power transmission, 2-pin	Differential	4 GHz / 5 Gbps Power: 16 A	●		●			●	●	●		●	●
H-MTD®	Standard automotive high-speed connector for Ethernet data transmission, 2-pin	Differential	20 GHz / 56 Gbps	●		●		● (MTD)	●		●			
RosenbergerHSD®	Standard automotive high-speed connector for differential data transmission, 4-pin	Differential	6 GHz / 8 Gbps	●		●		● (HSD-e)	●		●			
RJ45	Standard Ethernet connector with magnetic self-mating locking mechanism	Differential	100 Mbps / 10 Gbps	●		●					●			
HFM®	Miniaturized automotive connectors	Coaxial	20 GHz / 40 Gbps	●		●			●		●	●		
FAKRA	Standard automotive connectors	Coaxial	6 GHz / 12 Gbps	●		●			●		●	●		
PCB Connectors (different series)	High packing density due to minimum pitch and board-to-board distances	Coaxial	65 GHz / 40 Gbps									●		
FO Connectors and Cable Assemblies	Ruggedized multi-fiber connectors for high-speed data transmission, up to 24 fibers (multi- and single-mode)	Fiber Optic	20 GHz / 50 Gbps	●					●		●			
RoPo	Charging connector featuring secure bayonet locking (2 power pins / 4 signal pins)	Power	80 A							●				●
Circular Connector M12-Power	Standard industrial circular connectors for automation applications	Power	16 A							●				●
Multi-Power	Power Connector for low-power and high-power applications	Power	55 A											●
RoPD® - Rosenberger Power Data Connector	Hybrid connector with magnetic self-mating mechanism for combined power and data transmission	Magnetic Self-Mating	40 A / 4 data pins				●			●			●	●
Customer Specific Solutions		all Technologies		●	●	●	●	●	●	●	●	●	●	●
Comprehensive Portfolio of Cable Assemblies		Coaxial & Differential, Tor-sion-Resistant		●	●	●	●	●	●	●	●	●	●	●

RosenbergerHSD® – High-Speed-Data Connector

Power & data in one system (PoE/PoDL)

- Frequency range DC up to 6 GHz
- High data rates up to 8 Gbps
- Primary and secondary locking mechanism

 **Further information**
www.rosenberger.com/product/rosenberger-hsd

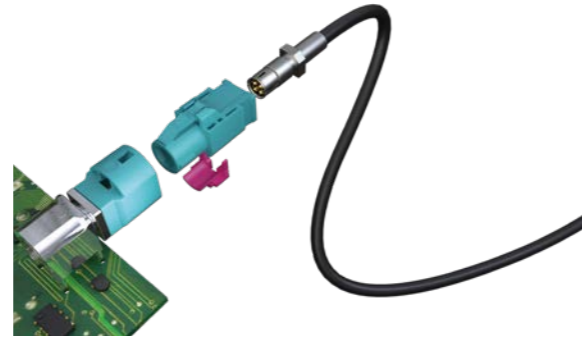

Single Pair Ethernet (SPE)

Communication from the sensor to the cloud

- Frequency range up to 4 GHz
- High data rates up to 5 Gbps
- Transmission distances of up to 1000 meters
- Compact design

 **Further information**
www.rosenberger.com/product/spe-industrial



RoPD® Rosenberger Power Data Interface

Fast, reliable, easy

- Magnetic self-mating mechanism
- Mating cycles: min. 2500
- Watertight and robust (IP65/IP67)
- Power transmission to 60 V DC/40A

 **Further information**
www.rosenberger.com/product/ropd



H-MTD® – High-Speed Modular Twisted-Pair Data

Portfolio

Wide product portfolio, expandable with MQS contacts for power transmission

- Frequency range DC up to 15 GHz
- High data rates up to 20 Gbps
- High density, compact housing

 **Further information**
www.rosenberger.com/product/h-mtd

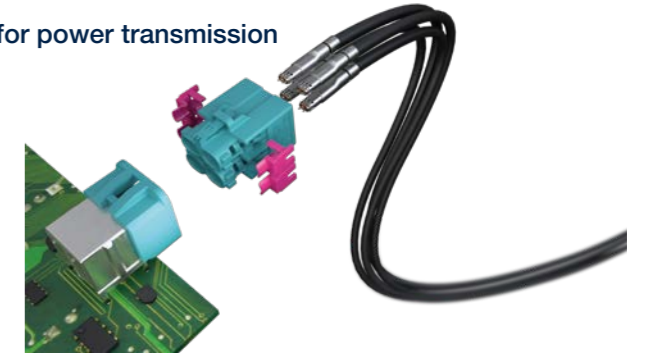

Circular Connectors

Connectivity all-rounder for signal, data, power

- Frequency range DC up to 500 MHz
- Different coding and number of contacts

 **Further information**
www.rosenberger.com/product/circular-connectors



RoPO – Rosenberger Power Bike

Fast, safe and easy charging on the standard power grid

- Secure bayonet locking mechanism
- Mating cycles: min. 10,000
- Watertight and robust (IP65/IP67)
- Power transmission to 500 V DC/80A

 **Further information**
www.rosenberger.com/product/ropo



RJ45

Industry standard and widely used

- Data rates up to 10 Gbps
- Mating cycles \geq 10,000

 **Further information**
www.rosenberger.com/product/magnetic-rj45



FAKRA

Proven camera connectivity – designed to prevent mismatching

- Frequency range DC up to 6 GHz
- High data rates up to 8 Gbps
- Primary and secondary locking mechanism

 **Further information**
www.rosenberger.com/product/fakra

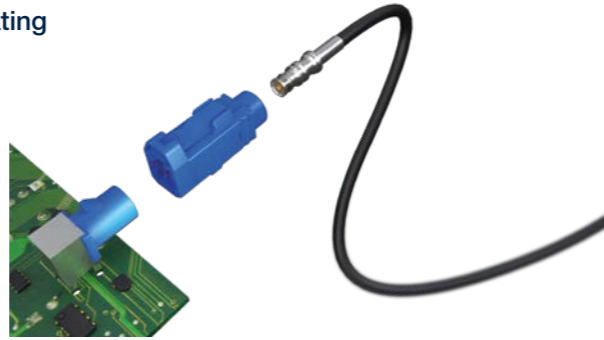

Mini SMP

Maximum RF performance in minimum space

- Frequency range DC up to 65 GHz
- Minimum board-to-board distance 7,94 mm
- Snap-on locking mechanism

 **Further information**
www.rosenberger.com/product/mini-smp



Modular Camera Solutions

Modular system for data transmission

Interfaces to the wiring harness:

- HFM® Frequency range up to 15 GHz (up to 20 Gbps)
- RMC® Frequency range up to 9 GHz
- FAKRA Frequency range up to 6 GHz (up to 8 Gbps)

 **Further information**
www.rosenberger.com/product/camera-solutions-for-automotive-applications



RoProxCon® Contactless Data and Power Transmission

Contactless power and data – robust, unlimited 360° rotation

- Power transmission up to 30 W
- Gigabit-Ethernet transmission
- High data rates up to 3.125 Gbps

 **Further information**
www.rosenberger.com/product/roproxcon-contactless



HFM® – High-Speed FAKRA-Mini

Miniaturized high-performance connector

- Frequency range DC up to 15 GHz
- High data rates up to 20 Gbps
- Compact structure – optimized use of space
- Robust design with excellent mechanical performance

 **Further information**
www.rosenberger.com/product/hfm-high-speed-fakra-mini

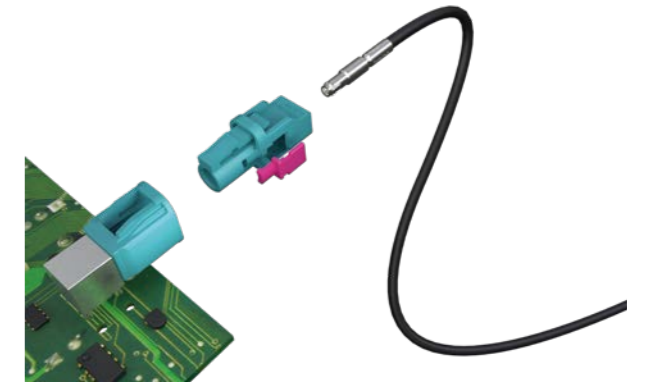

Portfolio

SMA

The proven standard for reliable RF connections

- Frequency range DC up to 18 GHz
- Screw-on locking mechanism
-

 **Further information**
www.rosenberger.com/product/sma



HySpeedVision (HYV)

All-in-One connectivity solution

- Frequency range DC up to 3.5 GHz
- High data rates up to 12 Gbps (up to 12 m)
- Power transmission 1.5 A at 24 V (on power pins)
- Push-pull locking mechanism

 **Further information**
www.rosenberger.com/product/hyspeedvision-hyv



FO Connectors and Cable Assemblies

Multifiber Connector with push-pull locking mechanism

- Multimode and singlemode
- Male, female and receptacle
- 4, 6, 8, 12 and 24 fibers
- MT ferrule
- IP67/ IP68 protection

 **Further information**
www.rosenberger.com/product/fibre-optic-patch-cords-equipment-cords



Cable Variety for Every Application – from Dynamic to Static

Whether highly dynamic movements in robotics and drag chain applications, flexible machine cabling, or fixed installations – Rosenberger is among the very few global manufacturers providing the optimal RF cable solution for every industrial camera integration and robotic application.

Our three proven cable types – for torsion and drag chain applications, classic energy chain routing, or static installations – stand out with application-specific features such as high cycle resistance, low attenuation, and compact designs.

The overview provides a quick guide to identify which cable best meets your technical requirements – powerful, robust, and integration-friendly.

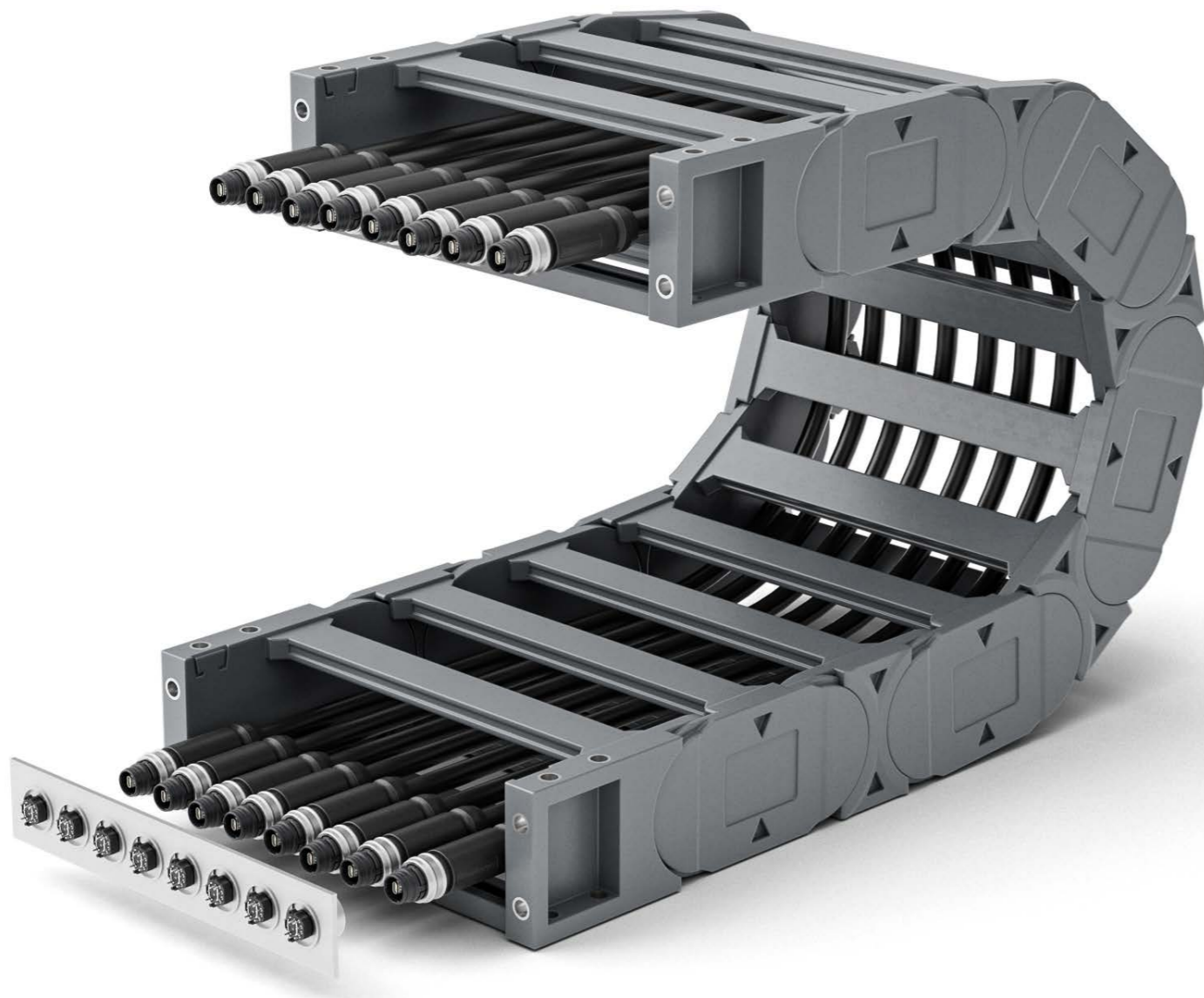

Rugged Cable Solutions for Robotics & Drag Chains Coaxial Cables

	Robot & Drag Chain	Drag Chain	Static
Cable type / designation	Similar RG316-d (CG: 03)	Similar RG58 (CG: 06)	RTK031 (CG: M4)
Torsional capability	Durability: 5 million cycles ±180° over 1 m		
Drag chain suitability	Durability: 3 million cycles minimum bending radius: 75 mm	Durability: 5 million cycles minimum bending radius: 75 mm	
Attenuation @ 3 GHz	<1.89 dB /m	<1.28 dB /m	<1.15 dB /m
Outer diameter	3.1 mm	5.6 mm	3.3 mm
Single bend radius	15 mm	22 mm	16 mm
Connector interface compatibility	FAKRA, HFM®, RMC®, standard Coax (BNC, SMA, SMB, SMP, MCX, ..)	FAKRA, standard coax (BNC, SMA, SMB)	FAKRA, HFM®, RMC®, standard Coax (BNC, SMA, SMB)
			A wide range of additional variants is available

Differential Cables

Rosenberger offers a comprehensive portfolio of high-quality differential cables for a wide range of connector types and applications; for example: 4-pin M12 / HSD, SPE cables. Our cable solutions ensure optimal electrical performance, signal integrity, and reliability – even under demanding conditions.

For customized solutions or further information, please feel free to contact us.

 **Further information**
www.rosenberger.com/products/cable-assemblies

Traditional connectors are the foundation of today's robust robotic systems. But when extreme freedom of movement, minimal maintenance, and maximum reliability are required, Rosenberger sets new standards with contactless technologies.

Benefits



Wear-Free Operation: Reliable, contactless connectivity – even under constant vibration



Unlimited Rotation: Stable, full-duplex data during continuous 360° rotation



Flexible Integration: Versatile mounting options for maximum design freedom



Reliable in Motion: No cable fatigue or breakage – perfect for highly dynamic environments



High Performance in a Compact Size: Delivers high data throughput and efficient power transfer in a minimal footprint



Robust and Durable: Maintains reliable performance even in harsh conditions with dust, dirt, or moisture



Challenge in Robotic Joints

The demand for fast and stable data connections continues to grow – especially in applications with rotating joints. Traditional slip ring systems quickly reach their limits due to mechanical wear, limited bandwidth, and unstable transmission.

Solution for Robotic Joints

This contactless technology enables wear-free, high-performance data transmission – ideal for continuous rotation and demanding robotic joints.

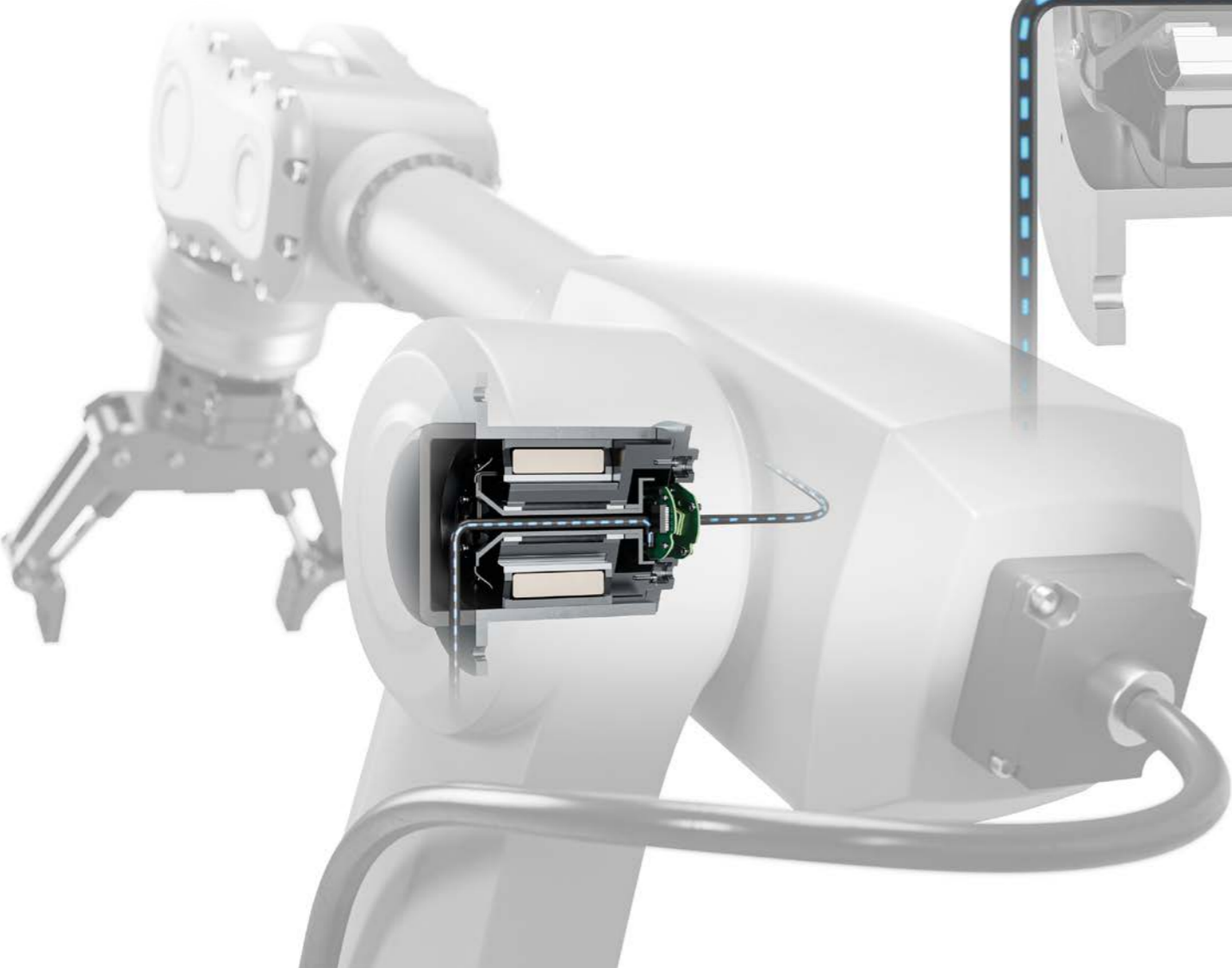
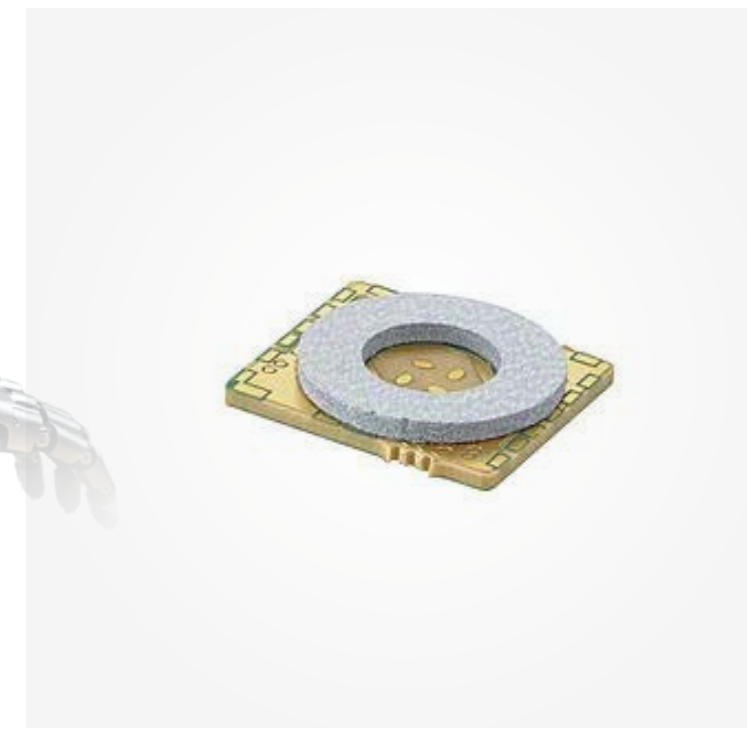

Benefits

- No mechanical wear
- Stable transmission during rotation
- High bandwidth capability
- Maintenance-free
- Compact integration
- Enhanced system uptime

Features

- Full duplex data transmission up to 3.125 Gbps, based on ST60
- High tolerance to radial and axial misalignment
- Stable data transmission with unlimited rotation
- Small form factor: 14.2 x 12.5 mm
- Low latency down to 7 ns
- Transmission through a wide variety of materials

Challenge of Automated Tool Changers

In robotic environments that demand frequent tool changes, conventional connectors quickly reach their limits. Repeated mating and unmating lead to wear, deformation, and contamination – ultimately reducing reliability and service life.

Solution for Automated Tool Changers

This contactless connection system enables the seamless and wear-free transmission of data and power – delivering consistent performance across unlimited mating cycles.

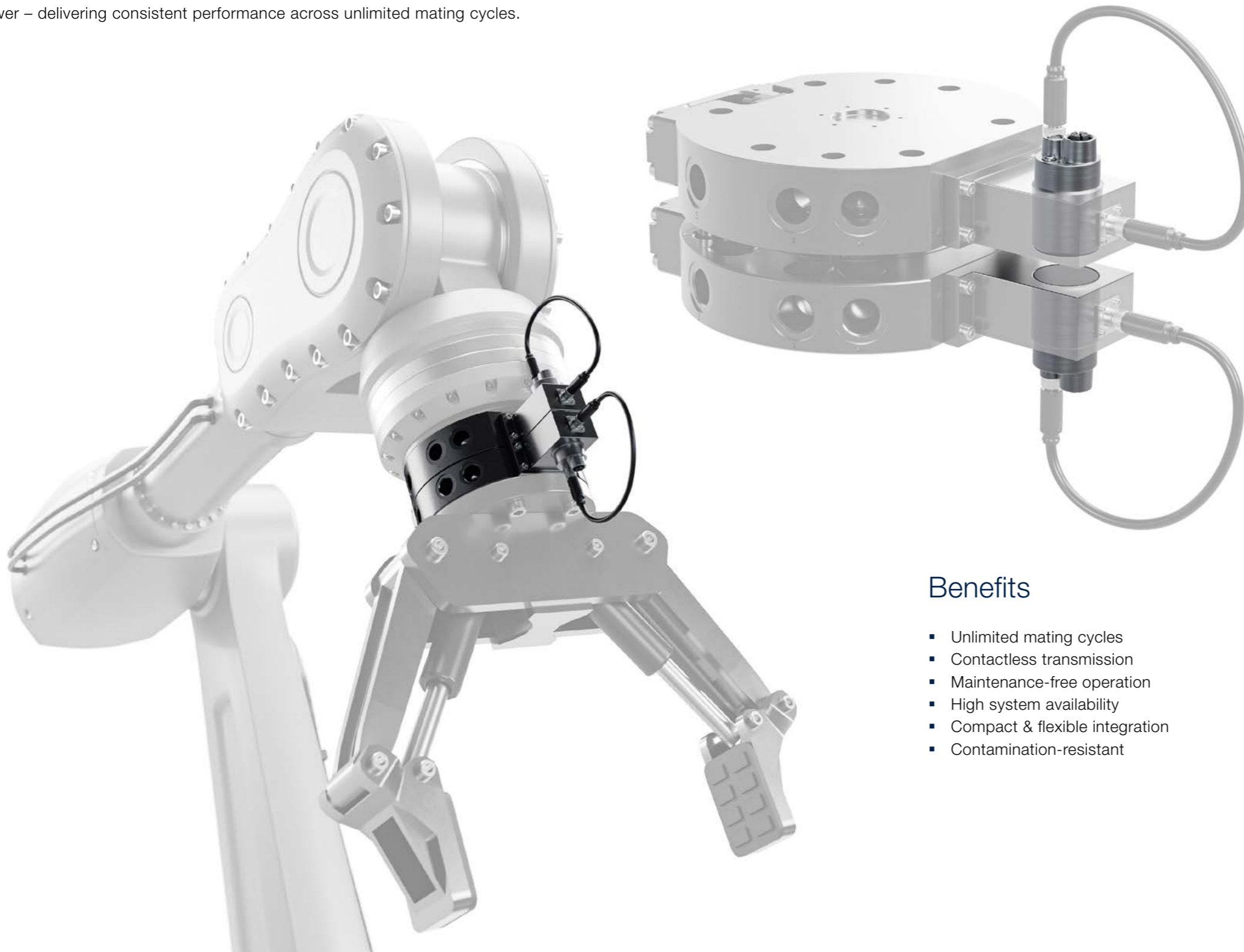

Benefits

- Unlimited mating cycles
- Contactless transmission
- Maintenance-free operation
- High system availability
- Compact & flexible integration
- Contamination-resistant

Features

- Full duplex transmission during 360° continuous rotation
- Gigabit-Ethernet transmission for Industrial Ethernet integrated (for example EtherCat and PROFINET)
- Individual localization and integration
- Transmission from device to device or to „other“ RoProxCon® through closed housings
- Hermetically sealed
- Certified plug-and-play solution

Challenge of Automated Test Systems

Automated testing environments demand precise, uninterrupted data transmission -even when perfect alignment of components cannot be guaranteed. Conventional wired or plug-in connections reach their limits in these situations, as they are sensitive to mechanical tolerances or positional deviations and additionally require manual mating operations.

What's needed is a durable, precise, robust, and contactless data interface that operates reliably throughout repeated, fully automated test cycles – without any manual intervention.

Solution for Automated Test Systems

RoProxCon® Hybrid ensures measurement reliability where precision reaches its limits. Its automatic, contactless connection maintains accurate data and power transmission — even in cases of misalignment or movement — making it ideal for demanding test setups.

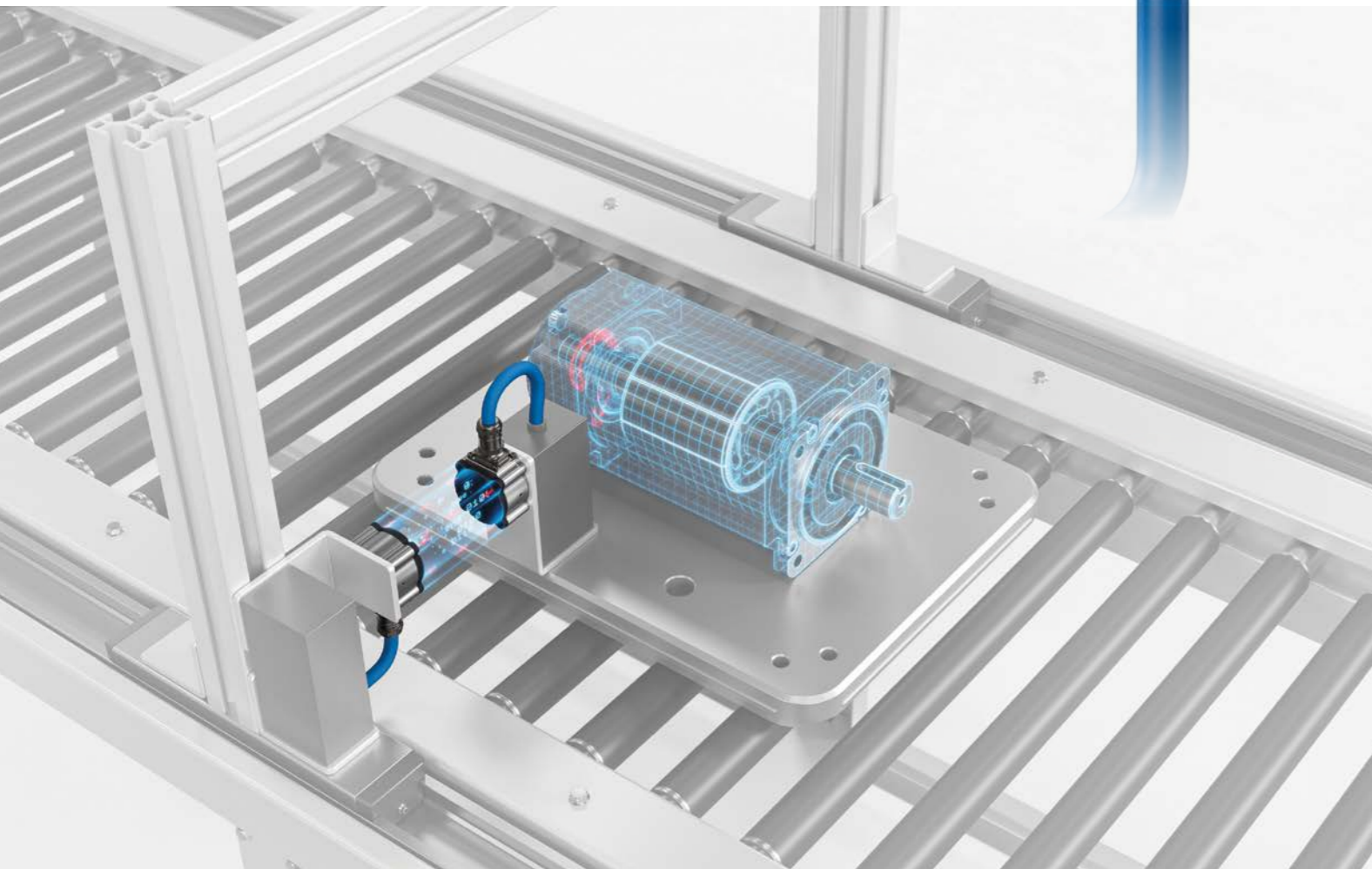



Benefits

- Misalignment-tolerant
- Contactless & precise
- Reduced test downtime
- Maintenance-free operation
- Flexible system integration
- Improved test reliability

Features

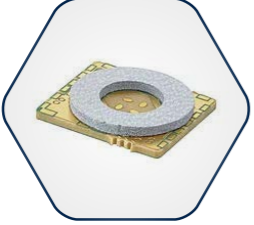
- Power transmission up to 30 W
- Full-duplex transmission during continuous 360° rotation
- Gigabit-Ethernet transmission for Industrial Ethernet integrated (for example EtherCat and PROFINET)
- Transmission from device to device or to „other“ RoProxCon® through closed housings
- Hermetically sealed
- Foreign object detection (FOD)

	SoM (System-on-Module)	Data	Hybrid
Product			
Data rate	up to 3.125 Gbps	up to 1 Gbps (Gigabit Ethernet)	up to 1 Gbps (Gigabit Ethernet)
Distance	up to 20 mm	up to 10 mm	up to 5 mm
Transmission	Data	Data	Data and power
Power	–	–	30 W
Misalignment	± 2 mm	± 2 mm	± 2 mm
Rotation	0 – 360°	0 – 360°	0 – 360°
Benefit	Compact plug-and-play solution. Easy to install	Direct integration onto the customer's PCB	Transmission of data & power

 **Further information**
www.rosenberger.com/product/roproxcon-contactless



Versatile:
Made for every application
Engineered for seamless integration into both existing infrastructures and future system architectures

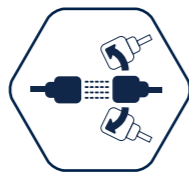

Reliable:
Built to perform
Delivers stable, high-performance connectivity even in the toughest environments

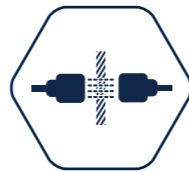

Borderless:
No physical limits
Contactless connectivity eliminates mechanical constraints and unlocks new levels of design freedom

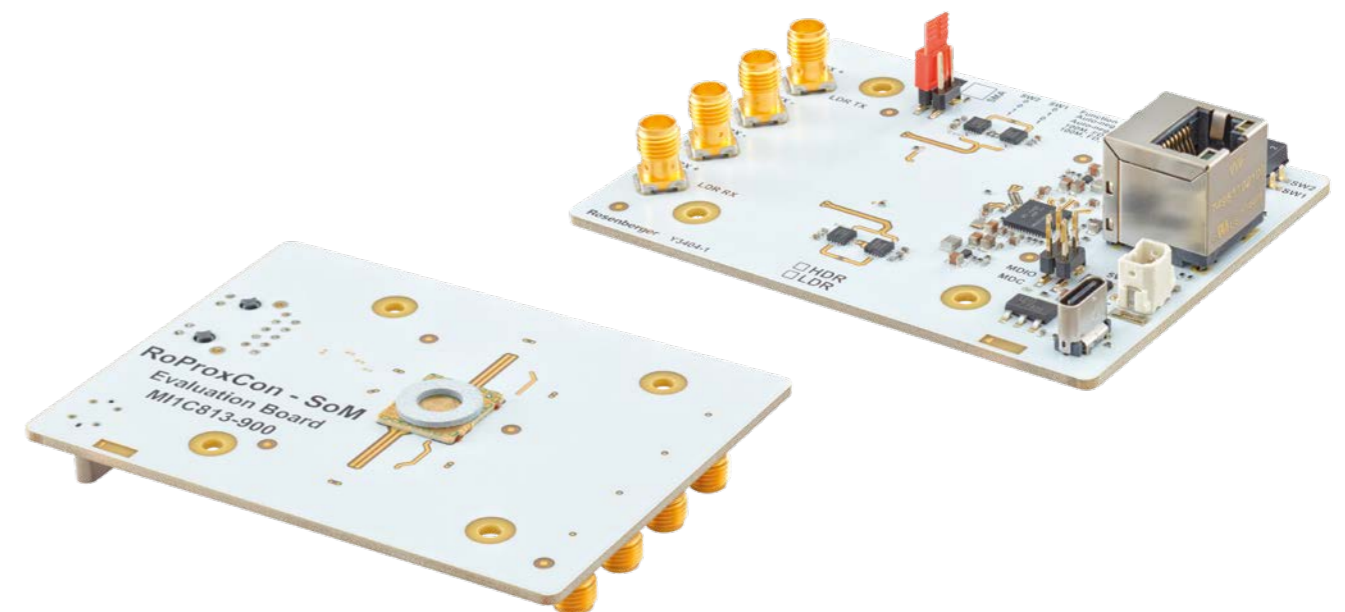

Evaluation Board

With the RoProxCon® Evaluation Board, Rosenberger offers a powerful platform for the development and integration of contactless transmission solutions. At its core is the compact RoProxCon® System-on-Module (SoM) – a high-frequency module designed for stable data transmission over short distances.

The board enables developers, OEMs, and system integrators to test the technology under realistic conditions and integrate it into customized applications.

Benefits

- **Simple Setup:** Fast and intuitive commissioning for immediate test readiness
- **High Flexibility:** Easily adaptable to meet specific testing and system requirements
- **Accelerated Development:** Delivers precise, repeatable results – speeding up development cycles
- **Versatile Application:** Supports coaxial outputs or an RJ45 connector (including Ethernet PHY)



Rosenberger is a leading provider of impedance-controlled and optical connectivity solutions as well as system components for high-frequency, high-voltage, fiber optic, and electronic technologies.

Rosenberger, a renowned global electronics manufacturer, is synonymous with cutting-edge technologies, exceptional development capabilities, and uncompromising quality. Headquartered in Germany, the Rosenberger Group maintains a worldwide presence through sales and manufacturing facilities, specialized in delivering a diverse array of standardized and tailor-made connectivity solutions across high-frequency, high-voltage, and fiber optic technologies.

Our solutions ensure the reliable transmission of signals, data, and power in the most demanding applications. Trusted by leading high-tech companies in mobile and telecommunications, industrial measurement technology, automotive electronics, medical and industrial electronics, data centers, and aerospace, Rosenberger's products stand out for their precision and unwavering reliability. The custom CNC machining division produces precision parts for various sectors, including automotive, commercial vehicles, shipbuilding, and traditional mechanical and plant engineering.

With a rich history dating back to its founding in 1958, Rosenberger has remained steadfast in its commitment to innovation and highest quality. As a family-owned business, we take pride in our enduring values and our dedication to our customers and employees alike.

Rosenberger maintains its position at the forefront of industry leadership with a dedicated team of approximately 15,000 talented individuals.

To learn more, visit www.rosenberger.com



Website

For more information refer to our website:
www.rosenberger.com/markets/robotics

Rosenberger

Rosenberger Hochfrequenztechnik GmbH & Co. KG

Hauptstraße 1 | 83413 Fridolfing

P.O. Box 1260 | 84526 Tittmoning

Germany

Phone +49 8684 18-0

info@rosenberger.com

www.rosenberger.com

Certified by IATF 16949 · DIN EN 9100 · ISO 9001 · ISO 14001 · ISO 45001 · ISO 50001

Order No.

10236439 · Info1RoboticFlyerEN

100/2026

Rosenberger® is a registered trademark of Rosenberger Hochfrequenztechnik GmbH & Co. KG.
All rights reserved.

© Rosenberger 2026